

KP1200-2600V~3200V

### Features

- All Diffused Structure
- Interdigitated Amplifying Gate Configuration
- Blocking capability up to 3200 volts
- Guaranteed Maximum Turn-Off Time
- High dv/dt Capability
- Pressure Assembled Device

### ELECTRICAL CHARACTERISTICS AND RATINGS

#### Blocking - Off State

| Device Type | V <sub>RRM</sub> (1) | V <sub>DRM</sub> (1) | V <sub>RSM</sub> (1) |
|-------------|----------------------|----------------------|----------------------|
| KP1200/26   | 2600                 | 2600                 | 2800                 |
| KP1200/28   | 2800                 | 2800                 | 3000                 |
| KP1200/30   | 3000                 | 3000                 | 3200                 |
| KP1200/32   | 3200                 | 3200                 | 3400                 |

V<sub>RRM</sub> = Repetitive peak reverse voltage

V<sub>DRM</sub> = Repetitive peak off state voltage

V<sub>RSM</sub> = Non repetitive peak reverse voltage (2)

|   |                                    |                    |
|---|------------------------------------|--------------------|
| Repetitive peak reverse leakage and off state leakage | I <sub>RRM</sub> /I <sub>DRM</sub> | 5 mA<br>120 mA (3) |
| Critical rate of voltage rise                         | dv/dt (4)                          | 1000 V/ μsec       |

#### Conducting - On State

| Parameter                                     | Symbol             | Min. | Max.                | Typ. | Units            | Conditions  |
|---|--------------------|------|---------------------|------|------------------|---|
| Average value of on-state current             | I <sub>T(AV)</sub> |      | 1200                |      | A                | Sinewave, 180° conduction, T <sub>c</sub> =70°C                                   |
| RMS value of on-state current                 | I <sub>TRMS</sub>  |      | 1884                |      | A                | Nominal value   |
| Peak one cycle surge (non repetitive) current | I <sub>TSM</sub>   |      | 14400               |      | A                | 10.0 msec (50Hz), sinusoidal wave-shape, 180° conduction, T <sub>j</sub> = 125 °C |
| I square t                                    | I <sup>2</sup> t   |      | 1.0x10 <sup>6</sup> |      | A <sup>2</sup> s | 10 msec   |
| Latching current                              | I <sub>L</sub>     |      | 1000                |      | mA               | V <sub>D</sub> = 12 V; R <sub>L</sub> = 12 ohms                                   |
| Holding current                               | I <sub>H</sub>     |      | 200                 |      | mA               | V <sub>D</sub> = 12 V; I = 2.5 A  |
| Peak on-state voltage                         | V <sub>TM</sub>    |      | 2.00                |      | V                | I <sub>TM</sub> =3000A; T <sub>j</sub> = 25°C                                     |
| Threshold voltage, low-level                  | V <sub>TO</sub>    |      | 1.06                |      | V                | T <sub>j</sub> =125°C   |
| Slope resistance, low-level                   | r <sub>T</sub>     |      | 0.35                |      | mΩ               | 1000A to 3000A  |
| Critical rate of rise of on-state current     | di/dt              |      | 200                 |      | A/μs             | Repetition  |

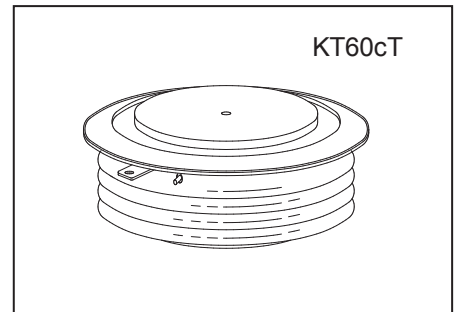

#### Notes:

- (1) All voltage ratings are specified for an applied 50Hz/60Hz sinusoidal waveform over the temperature range 0 to +125 °C.
- (2) 10 msec. max. pulse width
- (3) Maximum value for T<sub>j</sub> = 125 °C.
- (4) Minimum value for linear and exponential waveshape to 67% rated V<sub>DRM</sub>. Gate open. T<sub>j</sub> = 125 °C.
- (5) The value of di/dt is established in accordance with EIA/NIMA Standard JB/T 8950.2-2013

## ELECTRICAL CHARACTERISTICS AND RATINGS

### Gating

| Parameter                      | Symbol      | Min. | Max. | Typ. | Units | Conditions  |
|--------------------------------|-------------|------|------|------|-------|---|
| Peak gate power dissipation    | $P_{GM}$    |      | 20   |      | W     |   |
| Average gate power dissipation | $P_{G(AV)}$ |      | 4    |      | W     |   |
| Gate-trigger current           | $I_{GT}$    |      | 200  |      | mA    | $V_D = 12\text{ V}; R_L = 3\text{ ohms}; T_j = +25\text{ }^\circ\text{C}$ |
| Gate- trigger voltage          | $V_{GT}$    | 0.70 | 2.5  |      | V     | $V_D = 12\text{ V}; R_L = 3\text{ ohms}; T_j = +25\text{ }^\circ\text{C}$ |
| Peak negative voltage          | $V_{GRM}$   |      | 5    |      | V     |   |

### Dynamic

| Parameter                                 | Symbol   | Min. | Max. | Typ. | Units         | Conditions   |
|---|----------|------|------|------|---------------|--|
| Delay time                                | $t_d$    |      | 3.0  | 2.5  | $\mu\text{s}$ | $I_{TM} = 100\text{ A}; V_D = 67\% V_{DRM}$<br>Gate pulse: $V_G = 30\text{ V}; R_G = 10\text{ ohms};$<br>$t_r = 0.1\text{ }\mu\text{s}; t_p = 20\text{ }\mu\text{s}$         |
| Turn-off time (with $V_R = -5\text{ V}$ ) | $t_q$    |      |      | 500  | $\mu\text{s}$ | $I_{TM} = 1000\text{ A}; di/dt = -10\text{ A}/\mu\text{s}$<br>$V_R = 50\text{ V}; dV/dt = 30\text{ V}/\mu\text{s};$<br>$V_D = 67\% V_{DRM}; T_j = 125\text{ }^\circ\text{C}$ |
| Reverse recovery charge                   | $Q_{rr}$ |      |      | 3500 | $\mu\text{C}$ | $I_{TM} = 1000\text{ A}; di/dt = -10\text{ A/s};$<br>$V_R = 50\text{ V}; T_j = 125\text{ }^\circ\text{C}$  |

## THERMAL AND MECHANICAL CHARACTERISTICS AND RATINGS

| Parameter                             | Symbol            | Min. | Max.  | Typ.  | Units                     | Conditions          |
|---------------------------------------|-------------------|------|-------|-------|---------------------------|---------------------|
| Operating temperature                 | $T_j$             | -40  | +125  |       | $^\circ\text{C}$          |                     |
| Storage temperature                   | $T_{stg}$         | -40  | +140  |       | $^\circ\text{C}$          |                     |
| Thermal resistance - junction to case | $R_{\theta(j-c)}$ |      | 0.018 |       | $^\circ\text{C}/\text{W}$ | Double sided cooled |
| Thermal resistance - case to heatsink | $R_{\theta(c-s)}$ |      | 0.005 |       | $^\circ\text{C}/\text{W}$ | Double sided cooled |
| Mounting force                        | P                 | 25   | 31    | 27    | kN                        |                     |
| Weight                                | W                 |      |       | 0.593 | kg                        |                     |

\* Mounting surfaces smooth, flat and greased

KP1200-2600V~3200V

**Case Outline and Dimensions**